

Service-Information Motorcycle



©BMW of N.A.
Service Department

Group: 46
Frame

August 1990
46 029 90
(2419)

For USA Only

Side Stand Repair for R Models 1981 - 1984

Procedure: In some cases, the side stands and bearing brackets on models R80 - R100RT and R45 - R65, Mod. '81 have worn out (manufactured September, 1980 through August, 1984). Therefore, a Repair Kit has been developed consisting of two shouldered bushings. These are welded on to the side stand bracket to compensate for any play.

- Assembly:**
- Remove the exhaust header pipes and the old side stand assembly.
 - Carefully clean and degrease the side stand bracket and remove any burrs. Remove a large area of paint from all around the side stand bracket.
 - Insert the shouldered bushings and bearing bushing.

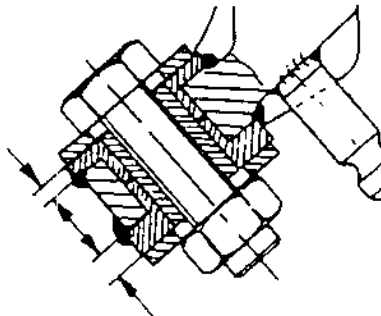
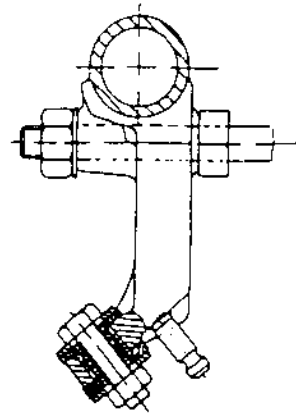

Bushing with thicker shoulder at bottom.

- Tighten bushings with M8 x 25 hex bolt and washers with an inside diameter of more than 12 mm. Make sure that the shouldered bushings are clamped together and do not press on the bearing bushing, which is longer than the two shouldered bushings. The bearing bushing is used during welding to ensure proper alignment of the shouldered bushings.

Note: You may wish to purchase an additional bearing bushing, shorten it, and use it as an alignment tool. This way, you don't need to use special washers for alignment.

Please initial and route to the following before filing				
Service	Parts	Sales	Warranty	Technicians

Warning:

Prior to welding, remove battery ground cable, temporarily pinch battery vent hose, ensure that fuel lines and float bowls are empty, and that no fuel is leaking from the fuel tank petcock(s).

- Use an inert gas welder (MIG) to weld the shoulder of the bushings on to the bearing bracket.
- Remove the clamps, clean the area around the weld, and repaint it using BMW matte black frame paint No. 51 91 1 453 483.
- Fit the new side stand. When folded out, it should point forward by approx. 10 degrees. It must retract automatically when the weight is taken off it.

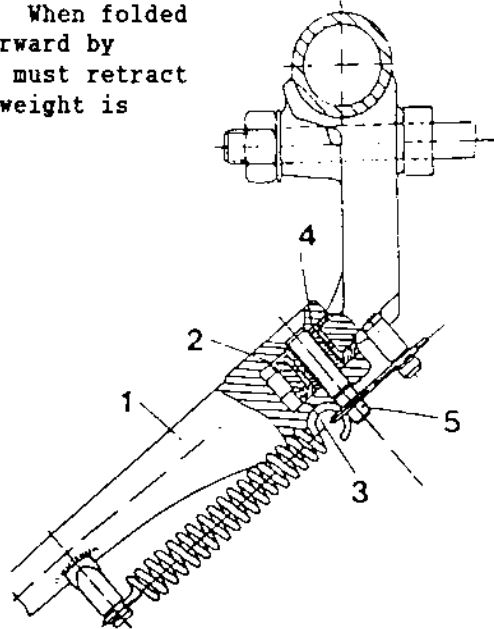

Parts:

Repair Kit consists of:

1. Side stand
2. Upper shouldered bushing
3. Lower shouldered bushing
4. Bearing bushing
5. Bearing pin bolt

(R80 - R100RT) Part No. 46 53 1 454 750
(R45 and R65) Part No. 46 53 1 454 751
Rubber bumper Part No. 46 52 1 236 522

We recommend the use of new:

Springs	Part No. 46 53 1 242 335
Brackets	Part No. 46 53 2 302 005

to ensure that the side stand retracts automatically.

Very truly yours,

BMW of North America, Inc.



Frank Stevens
National Service Manager
Motorcycle Group

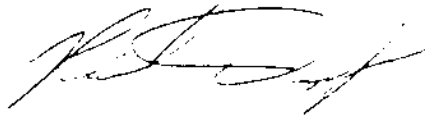

Richard Dampf
National Technical Manager

FS:jel/10.18