

Service-Information Motorcycle



BMW NA
Service Department

Group: 31
Front Forks

September, 1988
31 023 88
(2326)

For USA Only

Noisy Upper Fork Spring Support - '85 R65, R80, R100 Models

Problem: The fork spring support nut might work loose at the top fork bridge, causing an audible rattle.

Cause: The fork tube radius is pressing into the top fork bridge.

Remedy: Should this condition occur, install a shim:

Part no. 31 42 2 302 407

between the fork tube and top fork bridge to prevent the tubes from pressing into the casting.

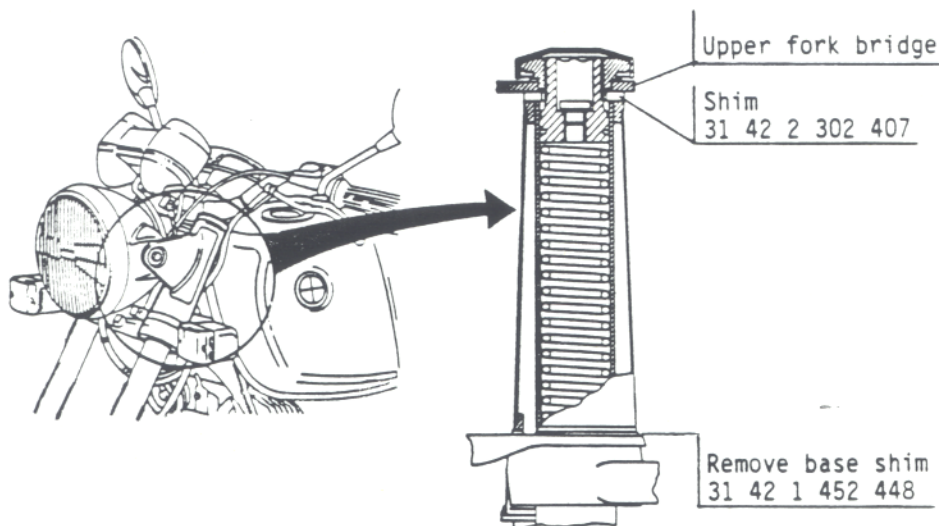

Procedure: RT Models:

- Remove the storage compartment lids.
- Use a protective cover for the fuel tank.
- Remove the fork tube pinch bolts from the lower fork bridge.
- Loosen the handlebar clamp bolts.
- Remove the cable straps on the handlebars and the one on the right fork tube.
- Tilt the handlebars back as far as possible.
- Remove the large nuts from the right and left fork tube upper supports.
- Using a screwdriver in the pinch bolt slots, spread the lower bridge clamp open.

- Pull the fork tube down approximately 30mm.
- Install a shim - part no. 31 42 2 302 407 - in between the fork tube and top bridge.
- Push the fork tube back up into the top bridge.
- Install a shim in the opposite side using the same procedure.
- Torque both large nuts to 106 Nm (77 ft/lb).
- Reposition and tighten the handlebars.
- Replace and torque lower fork bridge pinch bolts.
- Replace the storage compartment lids.
- Remove the protective covering from the fuel tank.
- Replace the cable straps previously cut from the handlebar and right fork tube.

Important:

The headlight holders on the basic R65 and R80 are secured between the upper and lower bridge with rubber rings. A base shim - part no. 31 42 1 452 448 - must be removed to reduce tension.

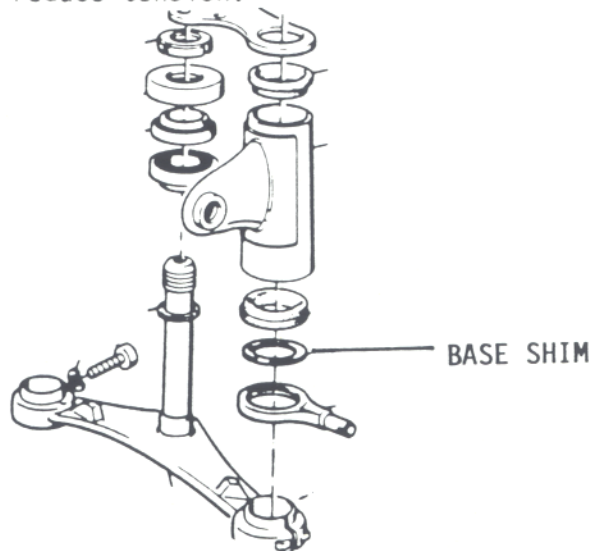

Warranty Status:

Parts and Labor are reimbursable under the provisions of the BMW Limited Motorcycle Warranty of three (3) years/unlimited miles, using a normal Warranty Claim Form:

Defect Code No.: 0000310500
 Flat Rate Code : WT
 Flat Rate Units: R65/R80 Basic 12 FRU
 R80RT/R100RS 13 FRU

Production Change:

The fork tubes have been given a slight chamfer instead of a large radius. Now that the fork tube surface is large, the nut cannot work loose.

Very truly yours,

BMW OF NORTH AMERICA, INC.

Frank Stevens
National Service Manager

Richard Dampf
National Technical Manager