

Service-Information Motorcycle



©BMW of N.A.
Service Department

Group: 46

Frame

March 1991
(Revised)
46 031 91
(2448)

For USA Only

R100GS/R100GS P-D Saddlebag Mounts - 1991 Models
Revised - April, 1991

R100GS P-D:

The R100GS P-D is manufactured with saddlebag mounts installed during production. The mounts are chrome plated so that they are more corrosion-resistant. A noticeable change this year is the new Matte Black cross support which improves the strength of the saddlebag mounts in rough-duty applications:

Chrome: 72 60 2 315 680 - Case Rod 72 60 2 315 674 - Clamp
07 11 9 932 073 - Washer

Black: 72 60 2 315 678 - Case Rod 72 60 2 315 672 - Clamp
07 11 9 932 099 - Washer

07 11 9 919 801 - Bolt (Can be used for either color)

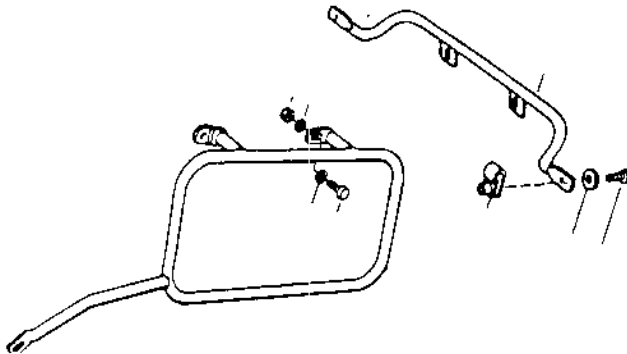

R100GS: If your customer chooses to install saddlebag mounts, the new cross support must also be installed.

- contd -

Please initial and route to the following before filing

Service	Parts	Sales	Warranty	Technicians

- Notes: - The cross support may also be fitted to 1988, 1989, and 1990 models at the owner's expense, with particular benefit during rough-duty applications.
- The cross support is mounted to the rear fender at the top two license plate mount bolts. Before tightening the two mounting bolts and two clamp bolts, insure that the cross support is not touching the tail light or the rear reflectors.

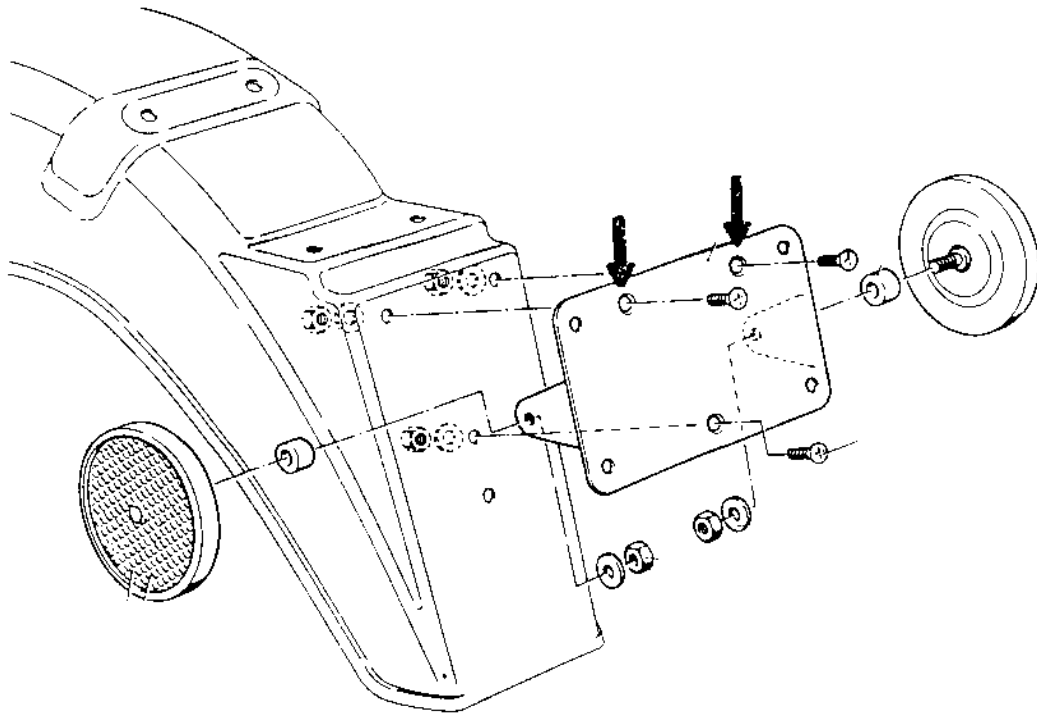

Very truly yours,

BMW of North America, Inc.

Frank Stevens
National Service Manager

Richard Dampf
National Technical Manager

FS:jel/366.24